

Pressure-Resistant and Explosion-Proof Electric Contact

Pressure Gauges and Pressure Switches

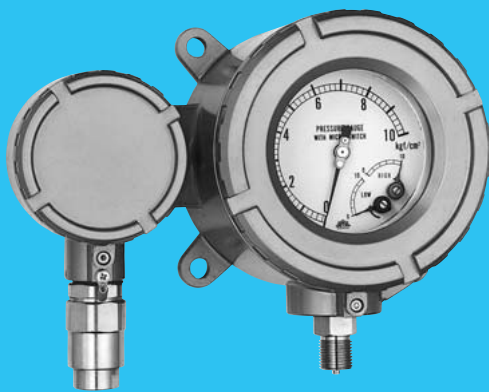

AdC-Type
Pressure Gauges with Contact

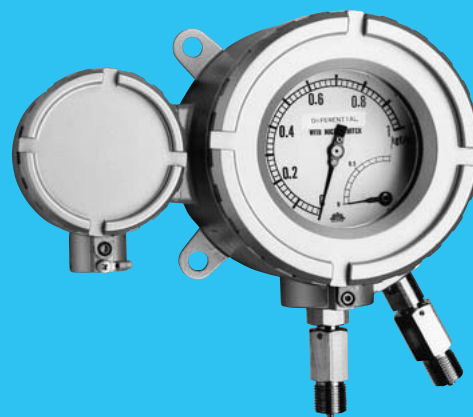

AdC-WType
Differential Pressure Gauges with Contact

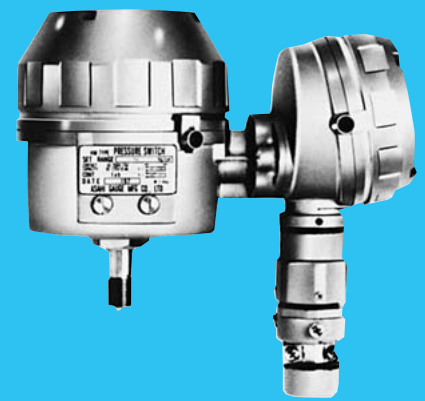

AdS-Type
Pressure Gauges with Contact

The following places are regulated by Japanese law as hazardous area that needs preventive safety measures: an atmosphere containing the vapor of inflammable material and a place where inflammable gas may concentrate to an explosive level or where explosive dust exists.

The electrical measuring instruments used at these places must have appropriate constructions specified in the Explosion Prevention Guidelines for Industrial Electrical Equipment instituted by the Industrial Safety Institute of Japan, based on the Industrial Safety and Sanitation Law. These instruments must carry

a label certifying that they have been approved by the Industrial Safety Research Association,

a Government-authorized inspection agency.

All Asahi Gauge products in this catalog have been approved by the association.



Description

This type of instruments has a field indicator dial. The indicator unit is located remotely from the electric contact switch unit, and they operate independently to each other (670).

A wide choice of contact types are available to satisfy specific application requirements.

The instrument is available with various attachments such as cable outlet, a diaphragm-seal unit, and so on to suit itself to individual applications.

Compact and light-weight.

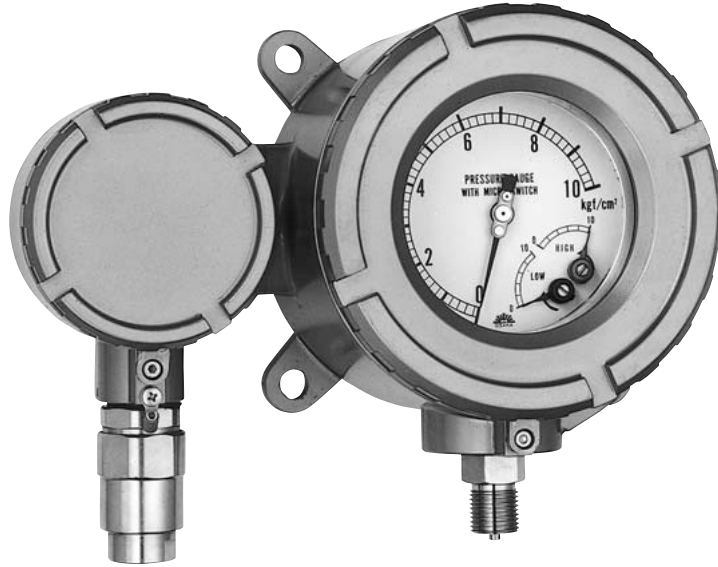

AdC-Type Pressure-Resistant and Explosion-Proof Electric Contact Pressure Gauges

Specifications

Type of explosion-proof construction:

Pressure-resistant and explosion-proof (d)

Explosion class: 2

Ignition group: G4

Class of hazardous area:

Division 1 area. Outdoor use

Model designation	Pressure range	Wet parts	Remarks
AdC - [] - [] H Upper limit L Lower limit H·L Upper/lower limit H1·H2 L1·L2 Type of contacts 670 Micro-switch 649 Indicator contact 647 Indicator contact relay 646 Indicator contact selfretaining relay 690 Photoelectric switch 671 Chamber Type with Micro-switch The mark [] indicates standard model. Weight about 5.5kg	0 ~ 5KPa ↓ 0 ~ 30KPa	Chamber SUS316	With frame arrestor
	0 ~ 0.08MPa ↓ 0 ~ 0.16MPa	Bourdon tube SUS316	
	0 ~ 0.2MPa ↓ 0 ~ 50MPa		

Important Note

The AdC models of 0.2MPa and under are required by law to have a flame arrestor to prevent reverse flame propagation. The arrestor can cause response delay for some sample fluids.

For pressure media which may cause critical delay of response, it is recommended to use one of the two measures: one is to add a water siphon to the pressure inlet of the gauge to convert the test medium pressure to water pressure, and the other is to add a diaphragm-seal unit.

Type of contact

Product name	Microswitch	Photoelectric switch
Model	AdC-670	AdC-690
Use	Alarm and controller	Alarm and controller
Type	SPDT	SPDT
Power	Not needed	100ACV or 200ACV
Switching mechanism	Snap action	Contactless
Capacity (resistance load)	AC250V-10A DC125V-0.4A	AC250V-5A DC100V-1A
Capacity (inductive load)	AC200V-1.5A, DC100V-0.03A	AC100V-2A, DC100V-0.5A
Accuracy	Within 2% FS	Within 1.6% FS
Repeatability	Within 1% FS	Within 1% FS
ON/OFF differential	1kg/cm ² and below: 15% 2 to 3 kg/cm ² : 10% 4 to 6 kg/cm ² : 7% 10kg/cm ² and over: 5%	Within 3% FS
Type of setting	Internal (external)	Internal (external)

Product name	Indicator contact	Indicator contact/relay	Indicator contact/self-retaining relay
Model	AdC-649	AdC-647	AdC-646
Use	Alarm	Alarm and simplified controller	Alarm and simplified controller
Type	SPST	SPDT	Self-retaining circuit
Power	Not needed	100VDC or 200VAC	100VAC or 200VAC
Switching mechanism	Contact	Contact	Contact
Capacity (resistance load)	100VAC-0.5A, 100VDC-0.2A	200VAC-5A, 100VDC-1A	200VAC-5A, 100VDC-1A
Capacity (inductive load)	100VAC-0.2A, 100VDC-0.1A	100VAC-2A, 100VDC-0.2A	100VAC-2A, 100VDC-0.2A
Accuracy	Within 1.6% FS	Within 1.6% FS	Within 1.6% FS
Repeatability	Within 0.5% FS	Within 0.5% FS	Within 0.5% FS
ON/OFF differential	0	0	0
Type of setting	Internal (external)	Internal	Internal

AdC-670

Conduit outlet GC1/2

d	f	H
1/4	16	138
3/8	18	141
1/2	20	143

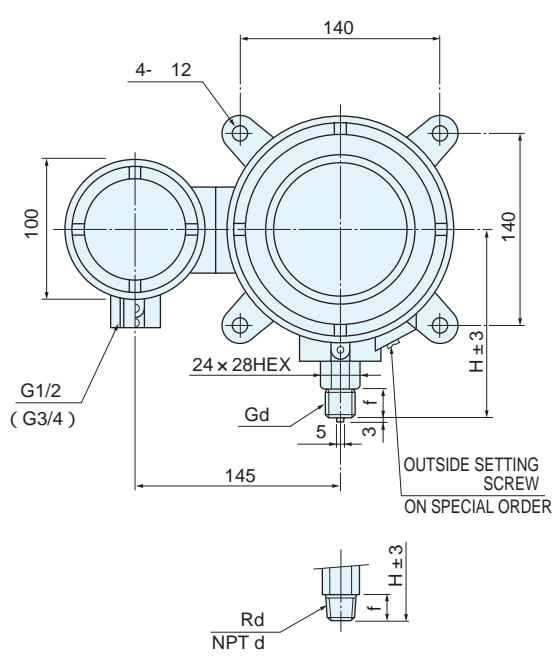

AdC-670

Pressure-proof packing type / version

d	f	H
1/4	16	138
3/8	18	141
1/2	20	143

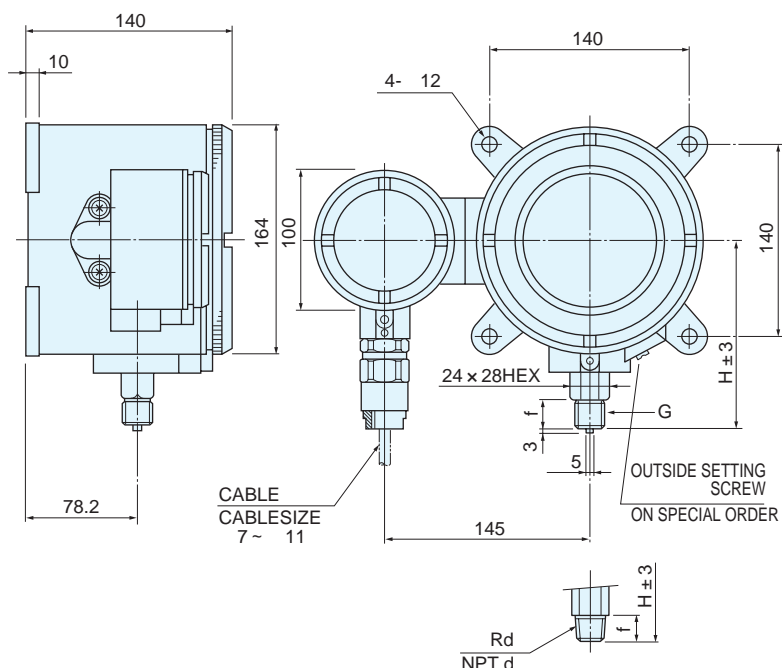

Description

The AdC-W Type model is a directly-mounted type pressure-resistant and explosion-proof differential pressure switch operating on a pressure difference between two different pressure both collected from individual sources. Typical applications include measuring of pipe-line flow rates, detection of filter-clogging, control of liquid level in a storage tank, etc.

Specifications

Type of explosion-proof construction: Pressure-resistant and explosion-proof (d)
 Explosion class: 2
 Ignition group: G4
 Hazardous area: Division 1 area. Outdoor use

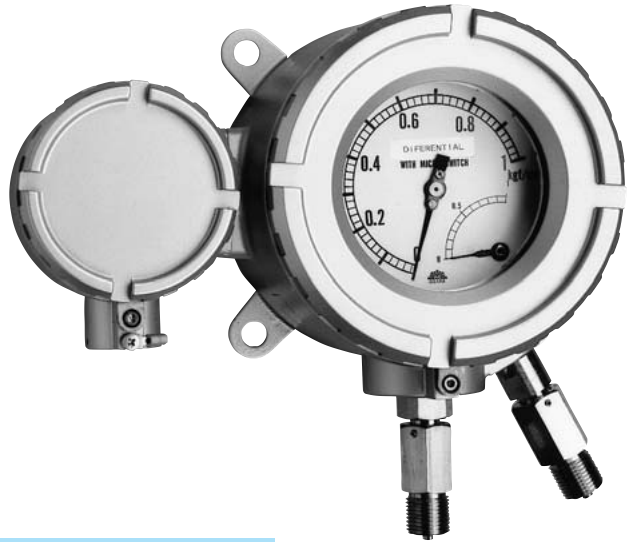

Explanation of Model Designation

AdC-W – Type of Contact – Number of Contacts – Differential pressure range

AdC-W Type Pressure-Resistant and Explosion-Proof Differential Pressure Switches

STANDARD SPECIFICATIONS

Model	Type of contact	Differential pressure range	Indicator	No. of contacts	One-Side press resistance MPa	Reference press MPa
AdC-W-787ME	Microswitch	0 ~ 5kPa 0 ~ 15kPa	No	1	0.05	5
		0 ~ 20kPa 0 ~ 0.08MPa	Yes	1		
			No	2	0.1	5
		0 ~ 0.1MPa 0 ~ 0.6MPa	Yes	1		
			No	2	1	5

The diaphragm type is available in a differential pressure range of 0 to 0.1 MPa or higher.

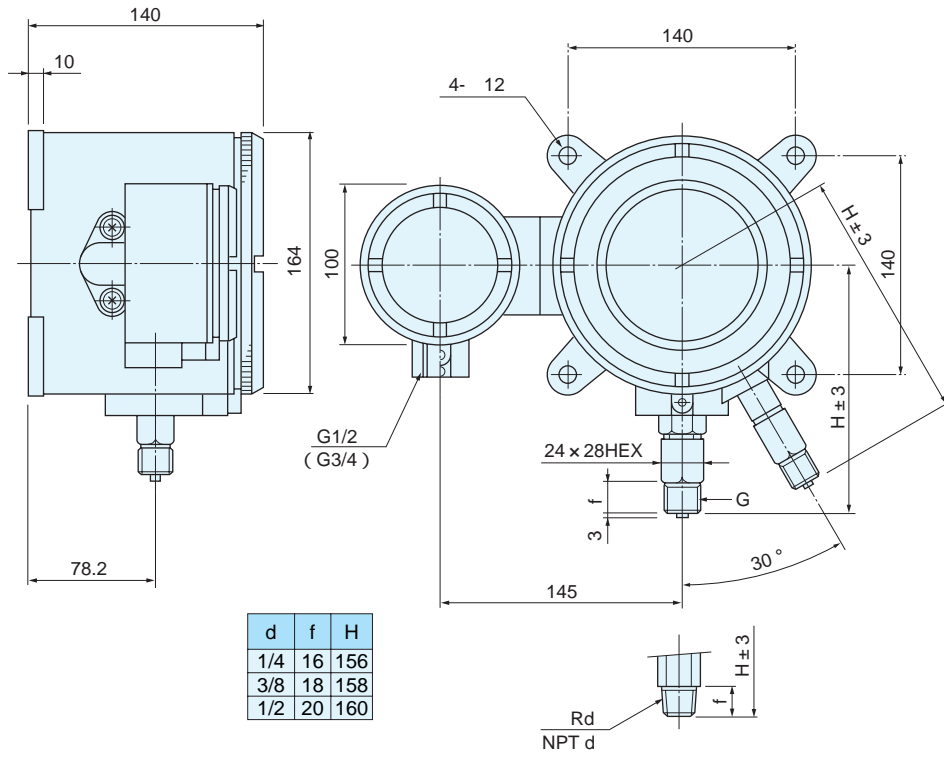

* Gauges with a packing-type wire outlet are made to order.

other	
Size	150 φ
Material of wet parts	316/NBR
Connection screw	G3/8, G1/2
On-Off differential	7%F. S-7%F. S Below
Repeatability	1%F. S
Accuracy of indicator	± 1.6%F. S
Operating temp	- 10 ~ + 40
Capacity	AC250V10A
(Resistance load)	DC125V0.4A
Elements	Bellows
Finish	Gray painting
Setting	internal
Weight	about 8.5kg

Description

Compact and lightweight (3.2kg).
 Easy to preset externally.
 Fast access to the movement can be achieved simply by removing the bezel for ease of service and check.
 The special inlet design eliminates the need for a flame arrestor so it provides response speed as fast as an ordinary pressure gauge.
 A variety of mounting styles are available, including self-standing, panel-mounting, pipe-stand-mounting, etc.

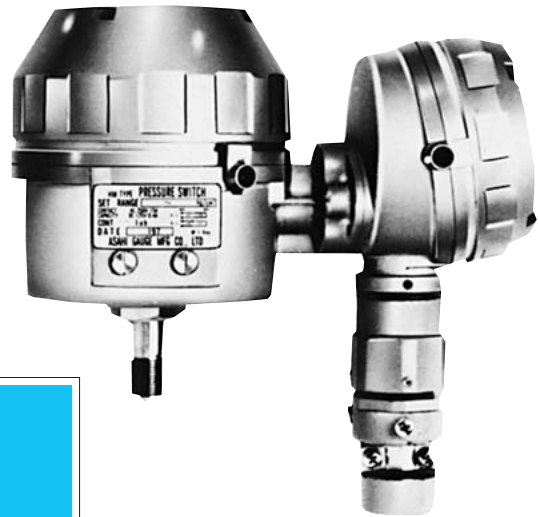

Small-Size Pressure-Resistant and Explosion-Proof Pressure Switches

Specifications

Type of explosion-proof construction:
 Pressure-resistant and explosion-proof type (d)
 Explosion class: 2
 Ignition group: G4
 Hazardous area: Division 1 area. Outdoor use

STANDARD SPECIFICATIONS

Type of contact	Capacity	Repeatability	Setting method	strength test	Finish
Microswitch	AC250V10A DC125V0.5A (Resistance load) AC200V1.5A DC100V0.03A (Inductive load)	1%FS	External driver	AC1500V 1min	silver gray

Acceptance No.	Model Designation	Range MPa	Material of Diaphragm-seal Unit	Number of contacts	ON/OFF Differential
24957	AdS- [] - [] - [] No. of contacts: 1 : 1 one contact Pressure range: [] 2F:2B Pipestand	0 - 0.08	316	1	14% FS ¹
		0.1	"	"	12% FS
		- 0.1	"	"	12% FS
		0.2	"	"	7% FS
24958	External lead inlet 4W: Wall mounting	0.3	"	1 or 2	7% FS
		0.4	"	"	7% FS
24959	C4: conduit GC1/2	0.6	"	"	6% FS
		1	"	"	6% FS
24960	C6: conduit GC3/4	2	"	"	4% FS
		2.5	"	"	4% FS
		3.5	"	"	4% FS
24961	P8: pressure-resistant packing, cable 6-8 P10: " 8-10 P12: " 10-12 P13: " 11-13 P15: " 13-15 weight about 3.2kg	5	"	"	4% FS
		7	"	"	4% FS
		10	"	"	4% FS
		10	"	"	4% FS

The mark [] indicates standard model.
 3%FS ON-OFF differential version is custom-made for 0 ~ 0.08MPa pressure ranges.

Direct Lead-Inlet Type

AdS —

1
2

 —

C4
C6

 PANEL

AdS —

1
2

 —

C4
C6

 PIPE STAND

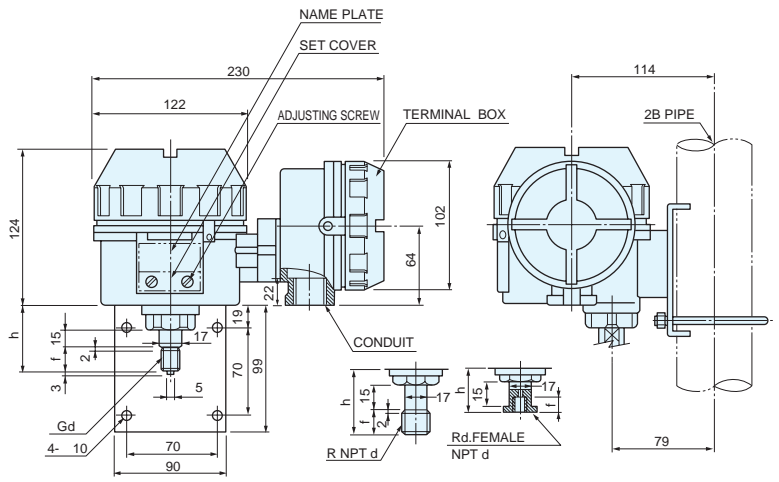
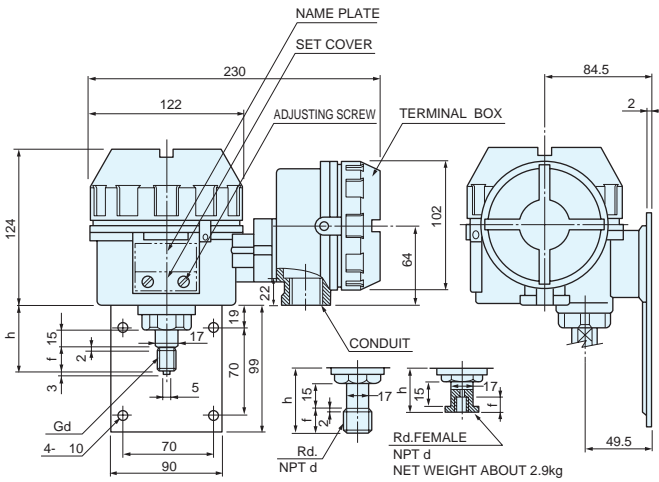

Lead Cable Outlet

Model	Size	Remarks
C4	GC1/2	Direct type
C6	GC3/4	"
P10	9 ~ 11 cable dia.	Pressure-resistant packing type, protective tube screw GC1/2
P12	10 ~ 12	" GC3/4
P15	13 ~ 15	" "

The mark indicates standard model.

Pressure-Resistant Packing Lead-Inlet Type

AdS —

1
2

 — P

12

 PANEL

AdS —

1
2

 — P

12

 PIPE STAND

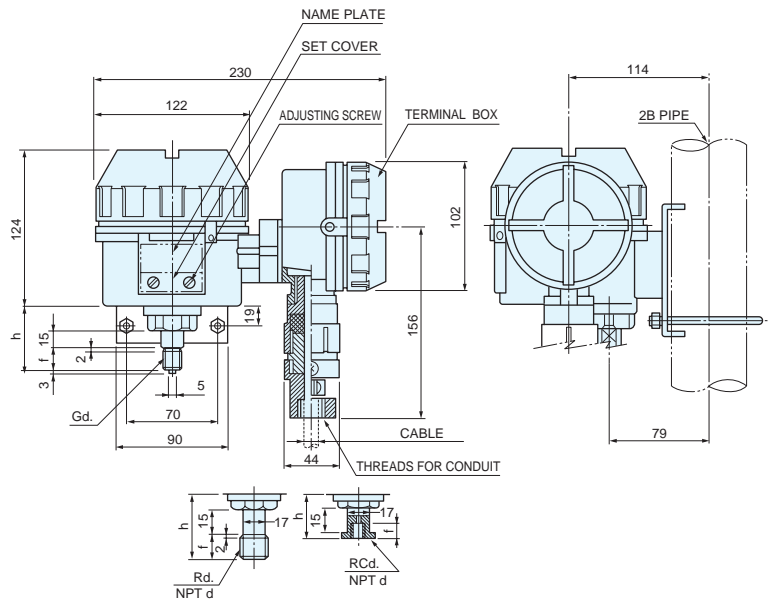
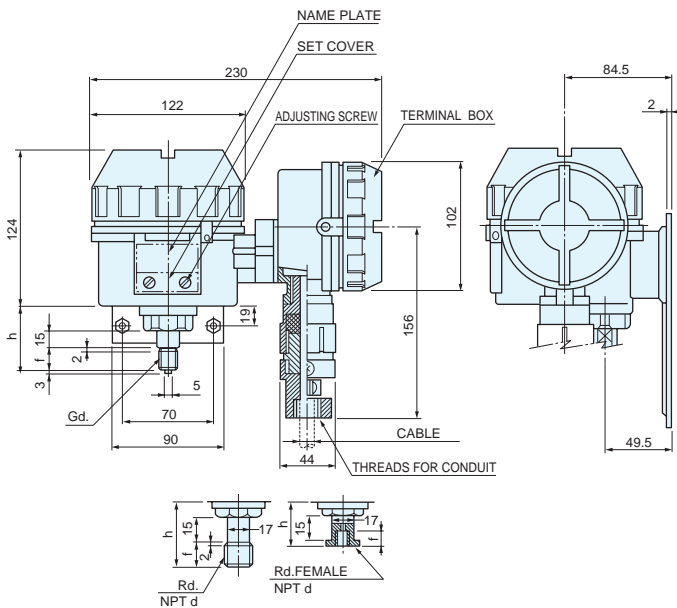

	d	f	h
RC1/4			
NPT1/4-F		12	42
G3/8		18	55
G1/2			
R1/2		20	57
NPT1/2			

Explosion-Proof Construction

Explosion-proof construction	d	Pressure-resistant explosion-proof construction (enclosed construction; inflammable sources are isolated in the case)
Explosion class	2	Minimum gap with 25mm-length of path which permits the flame propagation. Minimum gap, over 0.4mm up to 0.6mm.
Ignition group	G4	Ignition point, over 135°C up to 200°C.

Classification of Hazardous Areas

Hazardous areas are broken down into the following categories according to a period during which a hazardous atmosphere is continuously present, and the frequency and possibility of hazardous atmosphere occurrence:

Division 0 Area	An area in which a hazardous atmosphere is present or may be continuously present.
Division 1 Area	An area in which a hazardous atmosphere is likely to occur under the normal operating conditions, or by gas leakage or other accidents during servicing job.
Division 2 Area	An area in which a hazardous atmosphere is likely to occur under abnormal operation.

Example of Classification of Typical Explosive Gases

Ignition group / Explosion class	G1	G2	G3	G4	G5
1	Acetone	Ethanol	Gasoline	Acetaldehyde	
	Ammonia	Amylacetate-iso	Hexane	Ethyl ether	
	Carbon monoxide				
	Ethane	I-Butanol			
	Acetic acid				
	Ethyl acetate				
	Toluene				
	Propane				
	Benzene				
	Methanol				
	Methane				
2	Coal gas	Ethylene			
		Ethylene oxide			
3	Water gas	Acetylene			Carbon disulfide
	Hydrogen				

Note: In the above, d2G4 may apply to Class d1G1 through d2G4.

